

A Wideband CMOS Current-Mode Operational Amplifier and Its Use for Band-Pass Filter Realization

Mustafa Altun¹, Hakan Kuntman²

¹Istanbul Technical University, Faculty of Electrical and Electronics Engineering, Department of Electronics and Communication Engineering, 34469 Maslak, Istanbul, Turkey.

maltun@ehb.itu.edu.tr

²Istanbul Technical University, Faculty of Electrical and Electronics Engineering, Department of Electronics and Communication Engineering, 34469 Maslak, Istanbul, Turkey.

kuntman@ehb.itu.edu.tr

Abstract – In this paper, a CMOS current-mode operational amplifier (COA) based on a novel, class A input stage and a folded-cascode output stage is presented. The amplifier provides a 95 dB DC gain and a gain-bandwidth product exceeding 200 MHz. The COA is operated under ± 1.5 V voltage supplies and designed with 0.35- μm CMOS process. Additionally, COA-based band-pass filter is realized. In a multiple feedback band-pass filter topology, COA can be used instead of voltage amplifier to enhance the bandwidth of operation. The center frequency of the filter is 10 MHz.

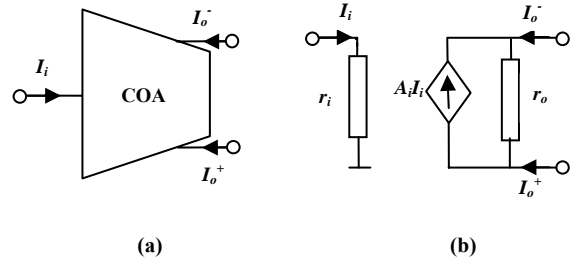

Fig. 1 (a) Circuit symbol (b) Equivalent circuit

I. INTRODUCTION

In recent years, current-mode approach has attracted more attention. Current-mode operational amplifiers (COAs) have several applications in closed-loop analogue signal processing, as conventional amplifiers (VOAs) perform the same function in the voltage domain [1]. Generally, COAs have better closed-loop bandwidth and enable high-speed operations with lower voltage supplies [2], [3].

COA ideally exhibits zero input resistance and infinite output resistance and current gain. The circuit symbol and the equivalent circuit are reported in Fig. 1.

It is not difficult to increase output resistance and current gain to reasonable values. However, to reduce the input resistance, some complicated negative feedback configurations must be applied [4], [5] and it generally worsens frequency response of the amplifier. Positive feedback is another solution for getting better input resistance [6]. However, in class AB operation it is not very applicable because of the poor stability of bias current. In this work, a new and simple approach is proposed to decrease input resistance.

For examining performance of the proposed COA, VOA is replaced with COA in a multiple feedback band-pass filter topology [7]. Using COA allows us to select bigger center frequency values, even higher than 1 MHz. Moreover, we can get output signal from two different nodes.

II. PROPOSED COA

As shown in Fig. 2, the proposed amplifier has very simple structure. W/L of transistors and DC values of the circuit are reported in Table 1 and Table 2 respectively.

The COA is formed by class A input and output stages. In the input stage M5, M4 and M3 compose positive feedback loop to reduce input resistance.

$$r_{in} \cong \frac{1}{(g_{m5} + g_{ds5})(g_{m2} + g_{ds2})} \left[(g_{ds2} + g_{m5} + g_{ds5}) - \frac{g_{m2}g_{m4}}{g_{ds4} + g_{m3} + g_{ds3}} \right] \quad (1)$$

Equation (1) represents input resistance of the proposed COA. The second term of (1) mainly affects input resistance value. If we select its value close to zero, r_{in} also goes near zero. Moreover, its value must bigger than zero to overcome the stability problem. The key point is choosing W/L of M3 a bit smaller than that of M2 for achieving better r_{in} at the cost of bigger input offset voltage.

Transistor M11 works like a resistance and only improves frequency response of the COA.

The output stage of the amplifier is folded-cascode structure. To get better frequency response, bias currents and differential pairs are implemented with PMOS transistors. Equation of output resistance is shown below

$$r_{out} \cong \left[\frac{g_{ds20,22}(g_{ds12,13} + g_{ds17,18})}{g_{m20,22}} + \frac{g_{ds19,21}g_{ds15,16}}{g_{m19,21}} \right]^{-1} \quad (2)$$

DC current gain and gain-bandwidth product are given by (3) and (4) respectively.

$$A_v(0) \cong \frac{g_{m12,13}}{2} \left[\frac{g_{ds9}g_{ds8} + g_{ds10}g_{ds6}}{g_{m9}g_{m10}} \right]^{-1} \quad (3)$$

$$f_{GBW} \cong \frac{1}{2\pi} \frac{g_{m12,13}}{2Cc} \quad (4)$$

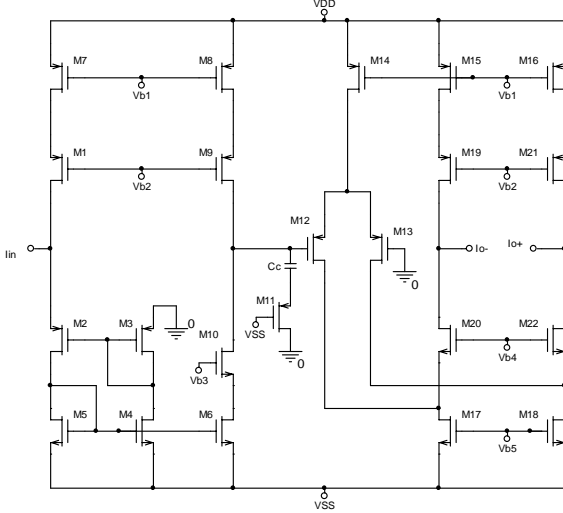

Fig. 2 Schematic of the proposed COA

III. FILTER REALIZATION WITH THE COA

As seen in Fig. 3, a well known band-pass filter topology is used. Because COA has better bandwidth compared to conventional op-amp, this band-pass filter can operate properly up to the value of frequency ≈ 250 MHz. Another advantage of using COA is being able to get two symmetrical output signals.

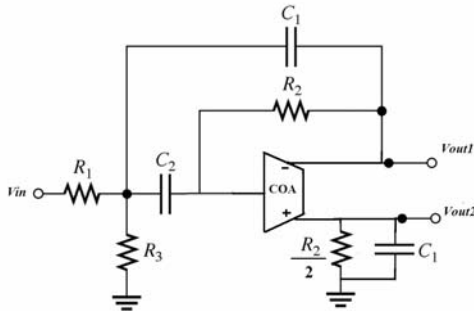

Fig. 3 Multiple feedback band-pass filter topology

Transfer function, center frequency and quality factor equations are given in (5), (6) and (7) respectively.

$$\frac{V_{out}}{V_{in}} = \frac{-s}{R_1 C_1} \frac{1}{s^2 + s \frac{(C_1 + C_2)}{C_1 C_2 R_2} + \frac{1}{C_1 C_2 R_2} \left(\frac{1}{R_1} + \frac{1}{R_3} \right)} \quad (5)$$

$$\omega_o = \sqrt{\frac{1}{C_1 C_2 R_2} \left(\frac{1}{R_1} + \frac{1}{R_3} \right)} \quad (6)$$

$$Q = \sqrt{\frac{C_1 C_2 R_2}{(C_1 + C_2)^2} \left(\frac{1}{R_1} + \frac{1}{R_3} \right)} \quad (7)$$

IV. SIMULATION RESULTS

A. Simulation results of Proposed COA

SPICE is used for simulation with the process parameters of a 0.35 μ m CMOS technology. BSIM3 parameter sets are used for modelling transistors of which threshold voltages are nearly 0.5 V for NMOS and -0.7 V for PMOS. The transistor widths range from 5 μ m to 120 μ m.

Table 3 summarizes the performance of the COA. The COA provides 95 dB dc gain, 202 MHz UGBW and 65° phase margin guaranteeing single pole behaviour throughout the UGBW. Because of the class A operation, speed of the COA is limited by quiescent current. Actually, except slew rate performance, other performance values are satisfactorily nice.

Transistors	W(μ m)/L(μ m)
M1, M9	30/1.4
M2	10/0.7
M3	9.2/0.7
M4, M5, M6	5/0.7
M7, M8	11/1.4
M10	5/0.7
M11	9/1
M12, M13	80/1
M14	140/1.4
M15, M16	70/1.4
M17, M18	41/1
M19, M21	120/1.4
M20, M22	30/1

Table 1 Transistor dimensions

Parameter	Value
$V_{DD} - V_{SS}$	± 1.5 V
V_{b1}, V_{b2}	0.5V, 0.2V
V_{b3}, V_{b4}, V_{b5}	0.3V, -0.2V, -0.7V
$I_{D1,2}$	15uA
$I_{D12,13}$	100uA
$I_{D17,18}$	200uA

Table 2 DC values of the COA

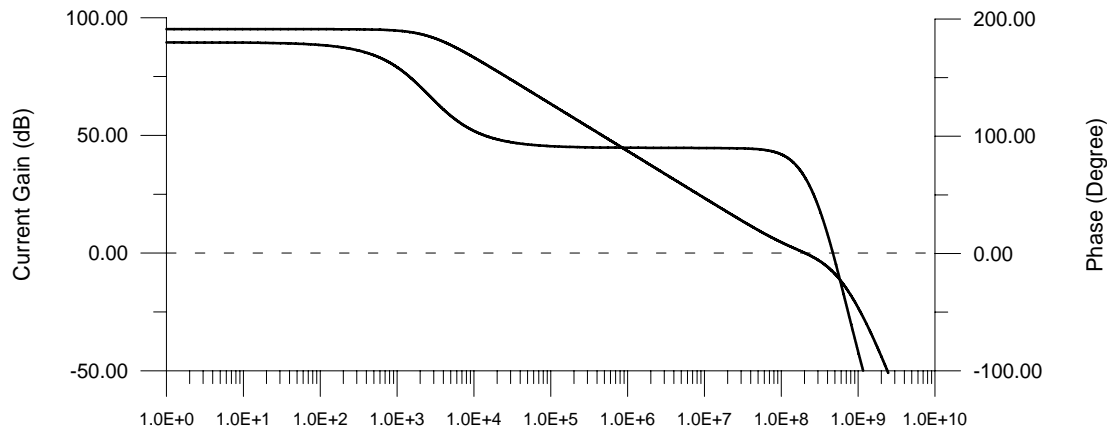

Fig. 4 Open-loop frequency response of the COA

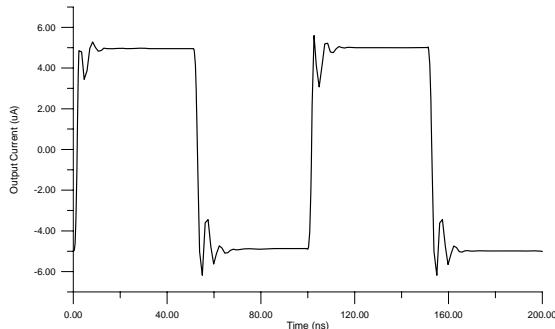

Fig. 5 Response of the COA in unity-gain feedback to a $\pm 5 \mu\text{A}$ input step

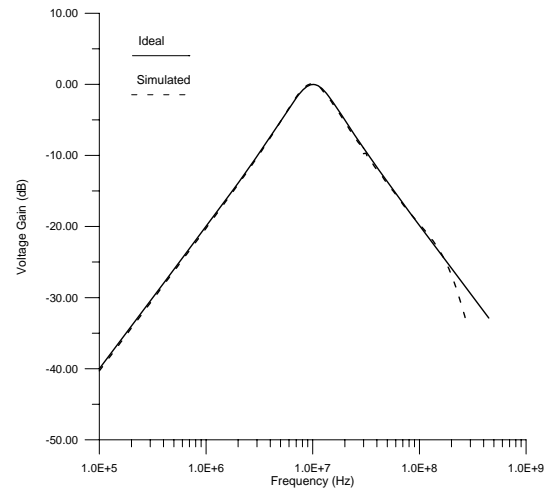

Fig. 6 Simulated and ideal filter responses

As shown in Fig. 6, although center frequency is selected 10 MHz, simulated and ideal filter responses are almost same up to $\approx 200\text{MHz}$.

Fig. 7 explains the transient characteristic of the filter. Up to 0.8 V peak to peak input signal value, THD is small enough to allow band-pass filter work properly.

Parameter	Value
Power Dissipation	1.3 mW
Open-Loop Gain	95 dB
GBW	202 MHz
Phase Margin ($C_c=0.3\text{p}$)	65°
Output Voltage Range	$\pm 1 \text{ V}$
Slew Rate	20uA/ns
Input Resistance	8Ω
Output Resistance	11.2 M Ω
Input Voltage Offset	$\approx 8\text{mV}$

Table 3 Performance parameters of the COA

B. Simulation results of the COA-based filter

These following values are selected to realize a COA based multiple feedback band-pass filter. Quality factor (Q) is 1, center frequency is 10 MHz and element values in the circuit are chosen as $R_1 = R_3 = R_2/2 = 3.18 \text{ k}\Omega$, $C_1 = C_2 = 5 \text{ pF}$.

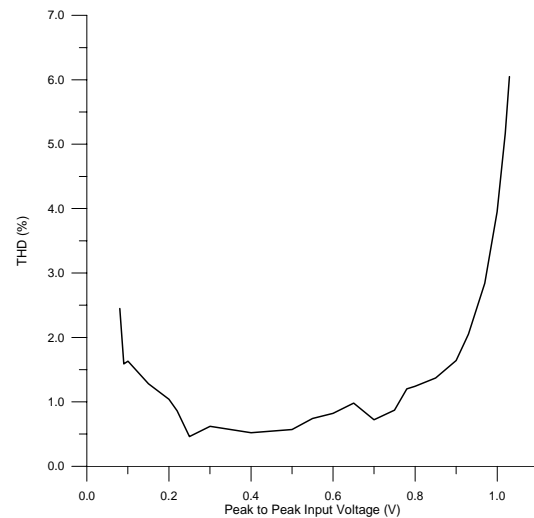

Fig. 7 Total Harmonic Distortion (THD) values of the filter versus input peak to peak voltage at 10 MHz frequency

V. CONCLUSION

In this work, a high performance COA is proposed. Higher than 200 MHz GBW is achieved with using very simple COA structure. It also offer very low input resistance $\approx 8\Omega$ and $\pm 1V$ output voltage swing.

In filter realization part, it can be easily seen that using COA instead of VOA apparently improves frequency range of the filter. While VOA-based multiple feedback band-pass filter works usually in some kHz center frequencies, 10 MHz is selected as a center frequency by using the COA.

REFERENCES

- [1] G. Palmisano, G. Palumbo, S. Pennisi, CMOS Current Amplifiers, Boston (MA), Kluwer Academic Publishers, pp. 1-9, 1999.
- [2] T. Kaulberg, "A CMOS Current-Mode Operational Amplifier," *IEEE J. Solid-State Circuits*, Vol.28, No.7, pp. 849-852, July 1993.
- [3] E. Abou-Allam, E. El-Masry, "A 200 MHz Steered Current Operational Amplifier in 1.2- μ m CMOS Technology," *IEEE J. Solid-State Circuits*, Vol.32, No.2, pp. 245-249, Feb. 1997.
- [4] W. Surakampontorn, V. Riewruja, K. Kumwachara and K. Dejhan, "Accurate CMOS-Based Current Conveyors," *IEEE Trans. Instrum. Meas.*, vol. 40, pp. 699-702, Aug. 1991
- [5] G. Palmisano and G. Palumbo, "A Simple CMOS CCII+," *International Journal of Circuit Theory and Applications* 23(6), pp. 599-603, November 1995
- [6] W. Wang, "Wideband class AB (push-pull) current amplifier in CMOS technology," *Electronics Letters*, 26, No. 8, pp 543-545, April 1990.
- [7] W. Jung, Op Amp Applications Handbook, USA, Analog Devices, pp. 374-392, 2005.