

Realisation of n th-order current transfer function employing ECCIIs and application examples

Mustafa ALTUN^{*1}, Hakan KUNTMAN¹, Shahram MINAEI² and Onur Korhan SAYIN¹

*. Corresponding Author: E-mail: altunmus@itu.edu.tr; Phone: +90 212 285 6419;
Fax: +90-212-285 35 65 (Department).

¹. Istanbul Technical University, Faculty of Electrical and Electronics Engineering, Department of Electronics and Communication Engineering, 34469, Maslak, Istanbul, Turkey.

Emails: onurkorhan@hotmail.com, kuntman@itu.edu.tr

². Dogus University, Department of Electronics and Communication Engineering, Acibadem, Kadikoy 34722, Istanbul, Turkey. E-mail: sminaei@dogus.edu.tr

Abstract

In this paper a universal n th order current-mode filter employing electronically tunable second-generation current conveyors (ECCII) and grounded passive elements is proposed. Since the current gain of the ECCII can be controlled electronically by adjusting the ratio of DC bias currents, it is possible to tune all the coefficients of the transfer function independently through the variable current gain of the ECCII. SPICE simulation results using TMS 0.35 μ m CMOS process model are included to verify the theory. Furthermore, a design example of a fourth order video band filter is given to illustrate the possibilities in analog circuit design provided by the topology introduced.

Keywords: Electronically tunable, Current Conveyor, Transfer function

1. Introduction

It is well known that current-mode circuits have greater linearity, lower power consumption, wider bandwidth and larger dynamic range than its voltage-mode counterpart [1]. As an important current-mode active device, the second-generation current conveyor (CCII) [2] is widely used by analog designers for realizing different types of filters [3-10].

In many applications it is required to change the coefficients of the filter transfer function (TF). Although operational transconductance amplifiers (OTAs) can be used to perform the

tuning, the nonvirtually zero voltage which exist between the input terminals of the OTAs is a considerable drawback in filter design [10]. Then further research has been focused on current conveyors with adjustable current gain [3-4, 10-15].

The electronically tunable current conveyor (ECCII) which has a controllable current gain was first proposed by Senani [11] using operational amplifier (OA) and operational transconductance amplifier (OTA). Then the ECCII was designed and realized in both CMOS and Bipolar technology [3-4, 12, 15].

High-order filters are needed and widely used for realization of communications systems. Several nth-order voltage- and current- mode transfer function synthesis methods and circuits are available in the literature employing active elements such as current conveyors (CCII) and current differencing buffered amplifiers (CDBAs) [6-9, 16]. However, these circuits suffer from a lack of electrical tunability which is very important for today's modern circuit design. High-order filters employing ECCIIs seem to bring solution to this problem [13-14].

In this paper a general circuit configuration for realizing nth-order current transfer function is derived using CMOS implementation of the ECCII reported in [15]. All coefficients of the current transfer function can be tuned independently by adjusting the current gain of ECCIIs used in the configuration. As an application, second-order current-mode filter which realizes low-pass, high-pass, band-pass and notch responses is designed. Furthermore fourth order video band filter is designed using second order low-pass and low-pass notch filters. Simulation results using transistor level implementation for the ECCIIs are given to confirm the theoretical analysis.

2. The ECCII and its CMOS implementation

The terminal relations of an ideal ECCII, with its electrical symbol is shown in Figure 1, can be given by

$$\begin{bmatrix} i_y \\ v_x \\ i_z \end{bmatrix} = \begin{bmatrix} 0 & 0 & 0 \\ 1 & 0 & 0 \\ 0 & \pm k & 0 \end{bmatrix} \begin{bmatrix} v_y \\ i_x \\ v_z \end{bmatrix} \quad (1)$$

The ECCII has a unity voltage gain (voltage follower) between terminals Y and X and a tunable current gain $\pm k$ between terminals X and Z. The latter property makes it different from a current conveyor (CC), which has a unity current gain. The Y and Z terminals are high impedance terminals, ideally infinite, whereas X terminal exhibits a low impedance level, ideally zero. The plus and minus signs of k denote positive (ECCII+) and negative (ECCII-) type conveyors, respectively.

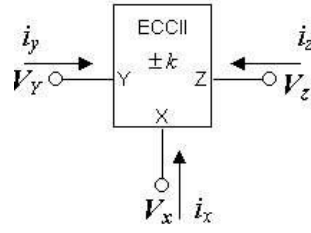

Figure 1. Electrical symbol of the ECCII.

Recently, an improved CMOS realization of the ECCII based on the circuit by Surakampotorn is introduced [15]. This CMOS implementation of the positive type electronically tunable current conveyor (ECCII+) is shown in Figure 2.

The output current of the circuit i_z can be calculated as [3]

$$i_z = nI_1 - nI_2 = n \left(\frac{I_B}{2I_A} \right) \cdot i_x = k \cdot i_x \quad (2)$$

where where $k = n \left(\frac{I_B}{2I_A} \right)$ is the small signal current gain of the amplifier and can be controlled electronically by means of DC bias currents I_A and I_B . The parameter n is the current multiplication factor of the current mirrors in output stage of the ECCII+. From Figure 2, it can be seen that the value of parameter $n=2$ because identical transistors (MC13, MC14) and (MK7, MK8) are used in parallel.

It should be noted that to implement a negative type electronically tunable current conveyor (ECCII-) it is sufficient to apply the currents $I_B + i_x$ and $I_B - i_x$ into terminals B and A of the small signal current amplifier, respectively.

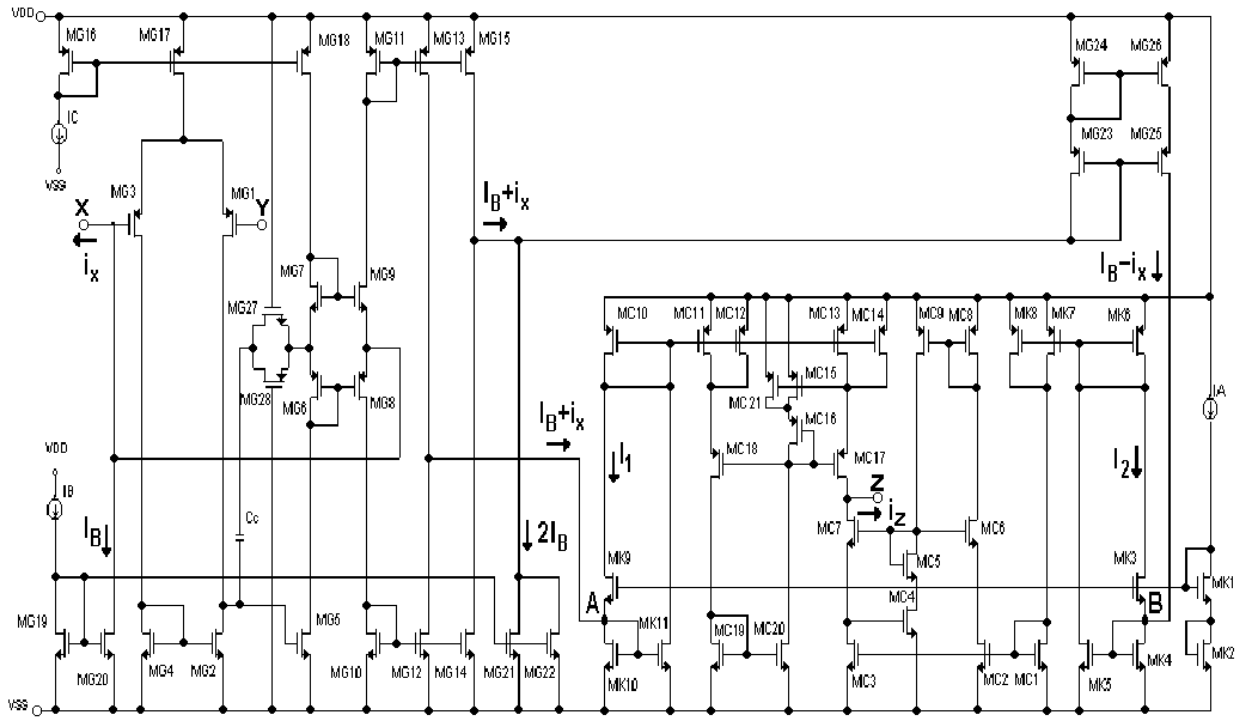

Figure 2. The proposed high performance ECCII+ [15].

3. Tunable n th-order current transfer function realization

A number of voltage and current transfer function synthesis have been presented [6-9]. However they suffer from a lack of electronic tunability. In this section a synthesis method for the realization of tunable n th-order current transfer function is proposed. The proposed method is based on realizing the n th-order current transfer function using a signal flow-graph and then obtaining, from the graph, the active-RC circuit involving ECCII \pm s.

Let the n th-order current transfer function be expressed as

$$T(s) = \frac{I_{out}}{I_{in}} = \frac{a_n s^n + a_{n-1} s^{n-1} + \dots + a_1 s + a_0}{s^n + b_{n-1} s^{n-1} + \dots + b_1 s + b_0} \quad (3)$$

where I_{in} and I_{out} are the input and output currents, respectively. The nominator in equation (3) is a polynomial with positive and negative real coefficients. The denominator is a Hurwitz polynomial with positive real coefficients. The signal flow-graph model for realizing the transfer function $T(s)$ is shown in Figure 3. This may be easily verified using the well-known Mason gain formula.

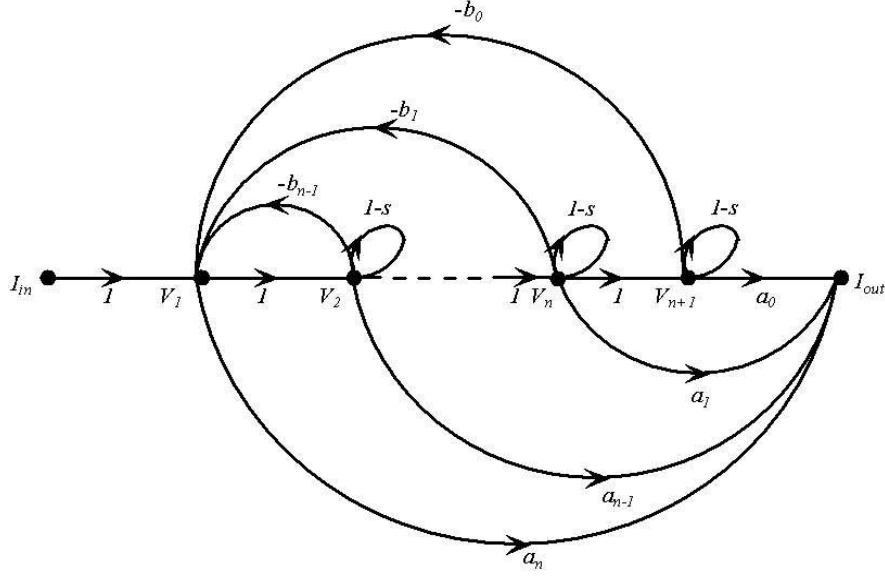

Figure 3. Signal flow-graph representing $T(s)$.

Using this signal flow-graph, the n th-order current transfer function $T(s)$ can be realized using positive and negative ECCIIs as shown in Figure 4. The circuit of Figure 4 includes $3n+2$ ECCIIs, $3n+2$ resistors and n grounded capacitors. All of the resistors and capacitors in the proposed circuit are grounded which is attractive for integrated circuit implementation. The current transfer function of the circuit can be found as

$$\frac{I_{out}}{I_{in}} = \frac{k_{a_n} s^n \left(\frac{R_1}{R_{n+2}} \right) + k_{a_{n-1}} s^{n-1} \left(\frac{R_1}{R_{n+4} R_2 C_1} \right) + k_{a_{n-2}} s^{n-2} \left(\frac{R_1}{R_{n+6} R_2 R_3 C_1 C_2} \right) + \dots + k_{a_0} \left(\frac{R_1}{R_{3n+2} (R_2 \dots R_{n+1}) (C_1 \dots C_n)} \right)}{s^n + k_{b_{n-1}} s^{n-1} \left(\frac{R_1}{R_{n+3} R_2 C_1} \right) + k_{b_{n-2}} s^{n-2} \left(\frac{R_1}{R_{n+5} R_2 R_3 C_1 C_2} \right) + \dots + k_{b_0} \left(\frac{R_1}{R_{3n+1} (R_2 \dots R_{n+1}) (C_1 \dots C_n)} \right)} \quad (4)$$

The coefficients k_{a_i} and k_{b_j} ($i=0 \dots n$ and $j=0 \dots n-1$) are the current gains of the ECCIIs, which can be controlled electronically. Each of the ECCII is used to adjust an individual coefficient in the current transfer function. It means that each coefficient can be tuned independently by adjusting the current gain of the relevant ECCII. This is the most important advantage of the circuit proposed compared to the conventional designs which makes it very attractive for analog designers.

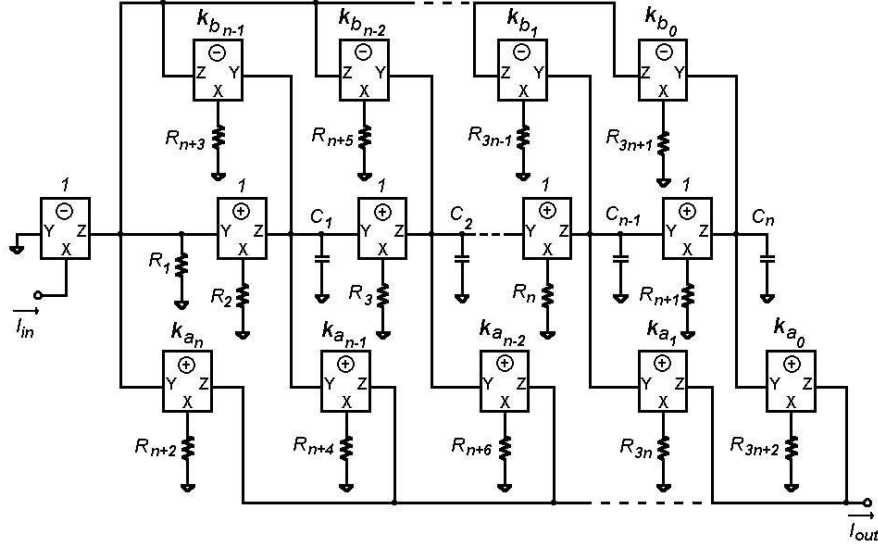

Figure 4. Implementation of the n th-order current transfer function.

For the realization of n th-order filter $3n+2$ active elements are necessary in general form which could be considered as a large element number. Note that this large number can be reduced for special realization purposes such as LP, HP, BP, BS filter functions by removing the unused sections depending on the aim of the design. The remaining part is necessary for the tuning of the filter parameters independently.

4. Application examples

Shown in Figure 5, the circuit which realizes second-order current transfer function is proposed as an application of this procedure. It can be considered as a filter with low-pass, high-pass and band-pass responses at high output impedance. The sum of the low-pass, highpass and bandpass responses yields the circuit transfer function as

$$T(s) = \frac{I_{out}}{I_{in}} = \frac{I_{HP} + I_{BP} + I_{LP}}{I_{in}} = \frac{k_{a_2} \left(\frac{R_1}{R_4} \right) s^2 + k_{a_1} \left(\frac{R_1}{R_6 R_2 C_1} \right) s + k_{a_0} \left(\frac{R_1}{R_8 R_2 R_3 C_1 C_2} \right)}{s^2 + k_{b_1} \left(\frac{R_1}{R_5 R_2 C_1} \right) s + k_{b_0} \left(\frac{R_1}{R_7 R_2 R_3 C_1 C_2} \right)} \quad (5)$$

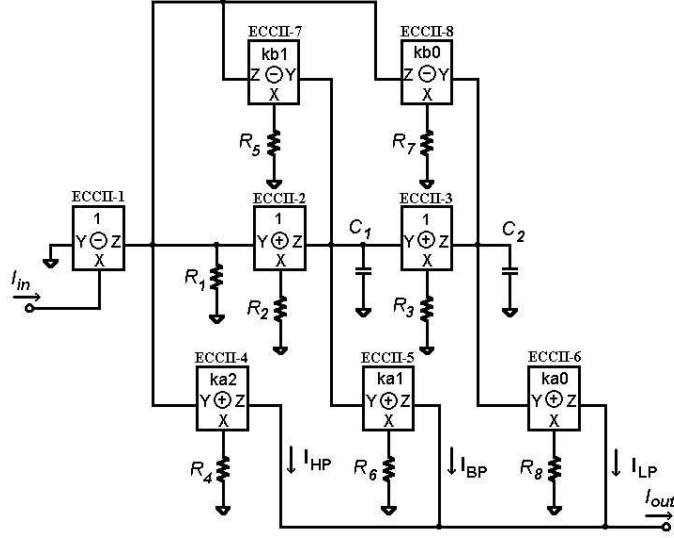

Figure 5. Second-order current-mode filter realization.

The ω_o and Q parameters of the filter are obtained as

$$\omega_o = \sqrt{\frac{k_{b0}R_1}{R_7R_2R_3C_1C_2}} \quad (6)$$

and

$$Q = \frac{R_5}{k_{b1}} \sqrt{\frac{k_{b0}R_2C_1}{R_1R_7R_3C_2}} \quad (7)$$

It can be seen that the parameter ω_o can be tuned electronically by adjusting k_{b0} . By keeping the value of k_{b0} constant and varying k_{b1} , the parameter Q can also be tuned without disturbing the parameter ω_o . Also sensitivity analysis of this filter gives:

$$S_{R_7}^{\omega_o} = S_{R_2}^{\omega_o} = S_{R_3}^{\omega_o} = S_{C_1}^{\omega_o} = S_{C_2}^{\omega_o} = -S_{k_{b0}}^{\omega_o} = -S_{R_1}^{\omega_o} = -\frac{1}{2}$$

$$S_{R_1}^Q = S_{R_7}^Q = S_{R_3}^Q = S_{C_2}^Q = -S_{k_{b0}}^Q = -S_{R_2}^Q = -S_{C_1}^Q = -\frac{1}{2}$$

$$S_{R_5}^Q = -S_{k_{b1}}^Q = 1$$

which are no more than unity in magnitude.

5. Simulation results

The performance of the proposed ECCII- based filter topology is verified using SPICE simulation program. The MOS transistors are simulated using TMS 0.35 μm CMOS process model parameters ($V_{\text{THN}}=0.62\text{V}$, $V_{\text{THP}}=-0.58\text{V}$, $\mu_{\text{N}}=460.5\text{cm}^2/\text{V}\cdot\text{s}$, $\mu_{\text{P}}=100\text{cm}^2/\text{V}\cdot\text{s}$, $T_{\text{OX}}=10\text{nm}$). The dimensions of the MOS transistors are listed in Table 1. The voltage supply used for the ECCII is $\pm 1.5\text{V}$. The biasing currents are selected as $I_A=I_B= 50\mu\text{A}$ which results in a current gain of unity for the ECCII. Also the biasing current $I_C = 100\mu\text{A}$ and compensation capacitor $C_C = 0.2\text{pF}$ are selected.

Table 1. Transistor dimensions of the ECCII circuit shown in Figure 2.

<u>Transistor</u>	<u>W/L (μm)</u>
<u>MG1, MG3, MG5 MG23-26</u>	<u>21/0.7</u>
<u>MG2, MG4</u>	<u>7/0.7</u>
<u>MG6, MG8, MG16, MG18, MG27,</u> <u>MG28</u>	<u>28/0.7</u>
<u>MG17</u>	<u>4.9/0.7</u>
<u>MG7, MG9, MC10-MC18, MC21</u>	<u>35/0.7</u>
<u>MG10, MG12, MG14, MG19-MG22</u>	<u>10.5/1.4</u>
<u>MG11, MG13, MG15, MK6-MK8</u>	<u>28/1.4</u>
<u>MK1- MK5, MK9- MK11</u>	<u>14/1.4</u>
<u>MC1-MC9, MC19, MC20</u>	<u>14/0.7</u>

Shown in Figure 5 the second-order current-mode filter of is simulated. The passive elements have been selected as: $R_5=R_6=5.65\text{ k}\Omega$, $R_i=8\text{ k}\Omega$ ($i=1\dots 4, 7, 8$), $C_1=C_2= 20\text{ pF}$ to obtain a lowpass, bandpass and highpass responses with a pole natural frequency of $f_o=1\text{ MHz}$ and a pole quality factor of $Q=0.707$. The simulation and ideal responses of the filter are shown in Figure 6. By adjusting the biasing current I_B of the ECCII, the tunability of the gain, quality factor and pole natural frequency of the filter are tested. For example, different values of $25\mu\text{A}$, $50\mu\text{A}$ and $100\mu\text{A}$ are selected for the biasing current I_B which results in a low-pass response current gain coefficient (k_{a0}) of 0.5, 1 and 2, respectively. The frequency response of the low-pass filter for different values of k_{a0} is shown in Figure 7.

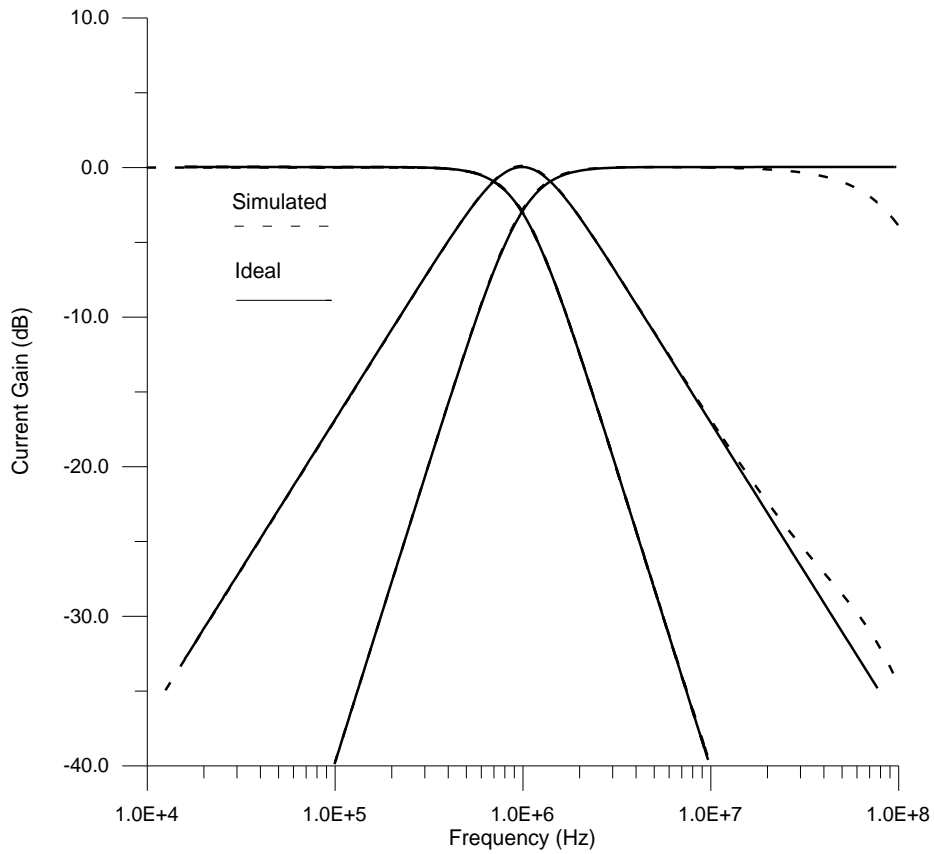

Figure 6. Simulated and ideal low-pass, band-pass, high-pass filter responses; $Q=0.707$, $f_o=995\text{kHz}\approx 1\text{MHz}$, $R_5 = R_6 = 5.65\text{k}\Omega$, $R_i = 8\text{k}\Omega$ (other resistance values), $C_i=20\text{pF}$, $k_i=1$ (gain of the current conveyors).

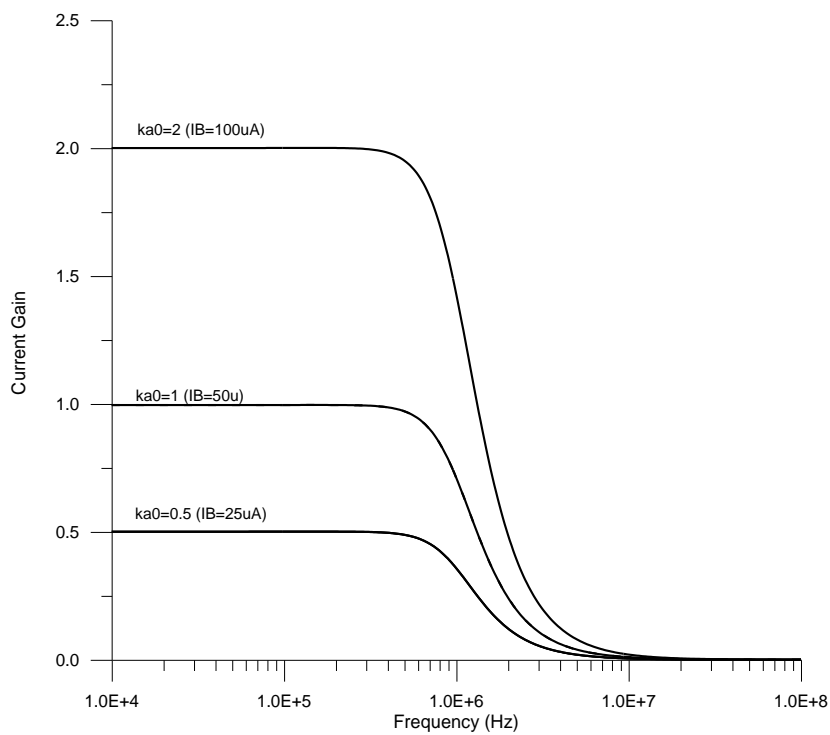

Figure 7. Tuning of the gain for low-pass response (Gain=0.5, 1, 2)

Figure 8 shows the tunability of the quality factor (Q) of the band-pass response by changing k_{b1} . Different biasing currents $I_B=25\mu\text{A}$, $50\mu\text{A}$ and $100\mu\text{A}$ are selected for the ECCII-5 and ECCII-7 with $R_5=R_6=11.3\text{ k}\Omega$ which result in $k_{b1}=0.5, 1, \text{ and } 2$, and $Q=2.828, 1.414, 0.707$ respectively.

Finally the tunability of the pole natural frequency of the band-pass response is tested by selecting different values for k_{b0} . Different biasing currents of $I_B=25\mu\text{A}$, $50\mu\text{A}$ and $100\mu\text{A}$ are selected for the ECCII-8 which result in $k_{b0}=0.5, 1 \text{ and } 2$, and $f_o=0.707\text{MHz}, 1\text{MHz}, 1.41\text{MHz}$, respectively, as shown in Figure 9. It can be easily observed that the simulation results are in good agreement with theoretical values.

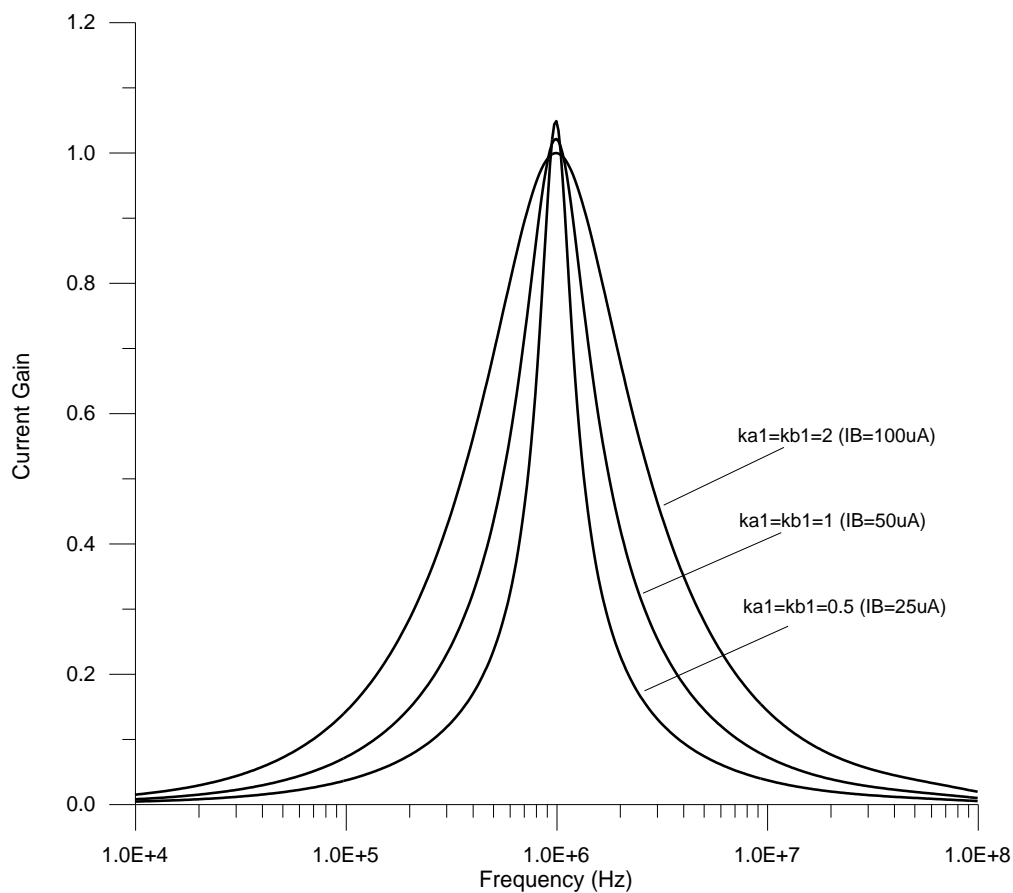

Figure 8. Tuning of the quality factor of band-pass response ($Q=0.707, 1.414, 2.828$)

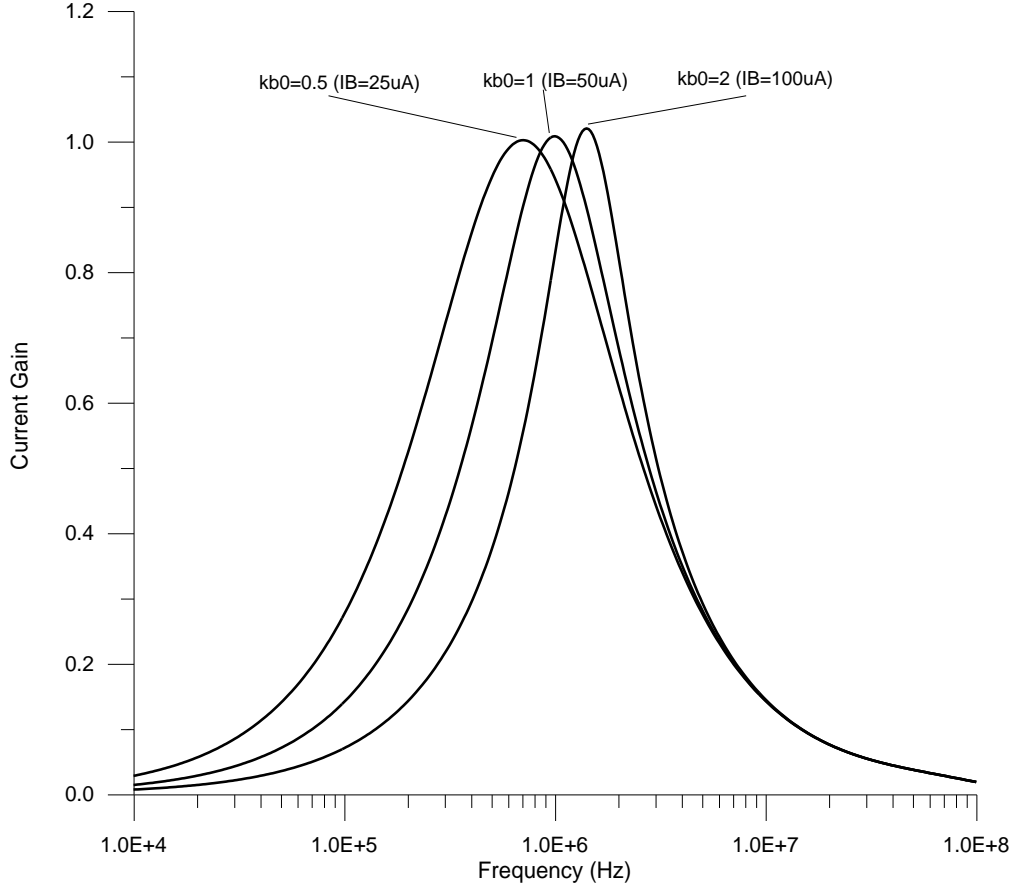

Figure 9. Tuning of the natural frequency of band-pass response ($f_0=0.707\text{MHz}$, 1MHz , 1.41MHz)

In the following, a design example of a fourth order video band filter is given to illustrate the possibilities in analog circuit design provided by the topology introduced. The transfer function of the filter is

$$H(s) = H \frac{s^2 + w_{z1}^2}{s^2 + \frac{w_{P1}}{Q_{P1}}s + w_{P1}^2} \frac{w_{P2}^2}{s^2 + \frac{w_{P2}}{Q_{P2}}s + w_{P2}^2} \quad (8)$$

where $H=w_{p1}^2/w_{z1}^2 \approx 2$, $f_{P1} = 3.46 \text{ MHz}$, $Q_{P1} = 3.42$, $f_{z1} = 4.83 \text{ MHz}$, $f_{P2} = 2.65 \text{ MHz}$, $Q_{P2} = 0.675$. This transfer function is realized by cascading a low-pass notch filter with a low-pass section. The filter is constructed by cascading of two sections illustrated in Figure 5 and choosing adequate biasing of ECCIIs. The element values are chosen as $R_5 = 2.7 \text{ k}\Omega$, $R_i = 4 \text{ k}\Omega$ (other resistance values), $C_i = 15 \text{ pF}$, $k_i = 1$ (gain of the current conveyors) for Low-pass section and $R_5 = 7.9 \text{ k}\Omega$, $R_4 = 4.6 \text{ k}\Omega$, $R_i = 2.3 \text{ k}\Omega$ (other resistance values), $C_i = 20 \text{ pF}$, $k_i = 1$ (gain of the current conveyors) for low-pass Notch section. Simulated filter frequency

response is illustrated in Figure 10. It can be easily observed from Figure 10 that the filter response is in good agreement with the ideal frequency response. Large signal behavior of the filter is investigated by observing the dependence of the output total harmonic distortion (THD) upon the input signal level. The result is illustrated in Figure 11 which shows that THD remains at reasonable levels (THD < 2%) if the peak to peak input current level is lower than 120 μ A. Figure 12 illustrates the dependence of Total Harmonic Distortion (THD) on the load resistance and output peak-to-peak voltage for 50 μ A peak-to-peak input current at 3 MHz frequency. The output voltage can be calculated as $V_O = I_{out} \times R_L$. It can be observed that the THD remains lower than 1.5% for a load resistance of 17k which yields 0.85V output voltage range.

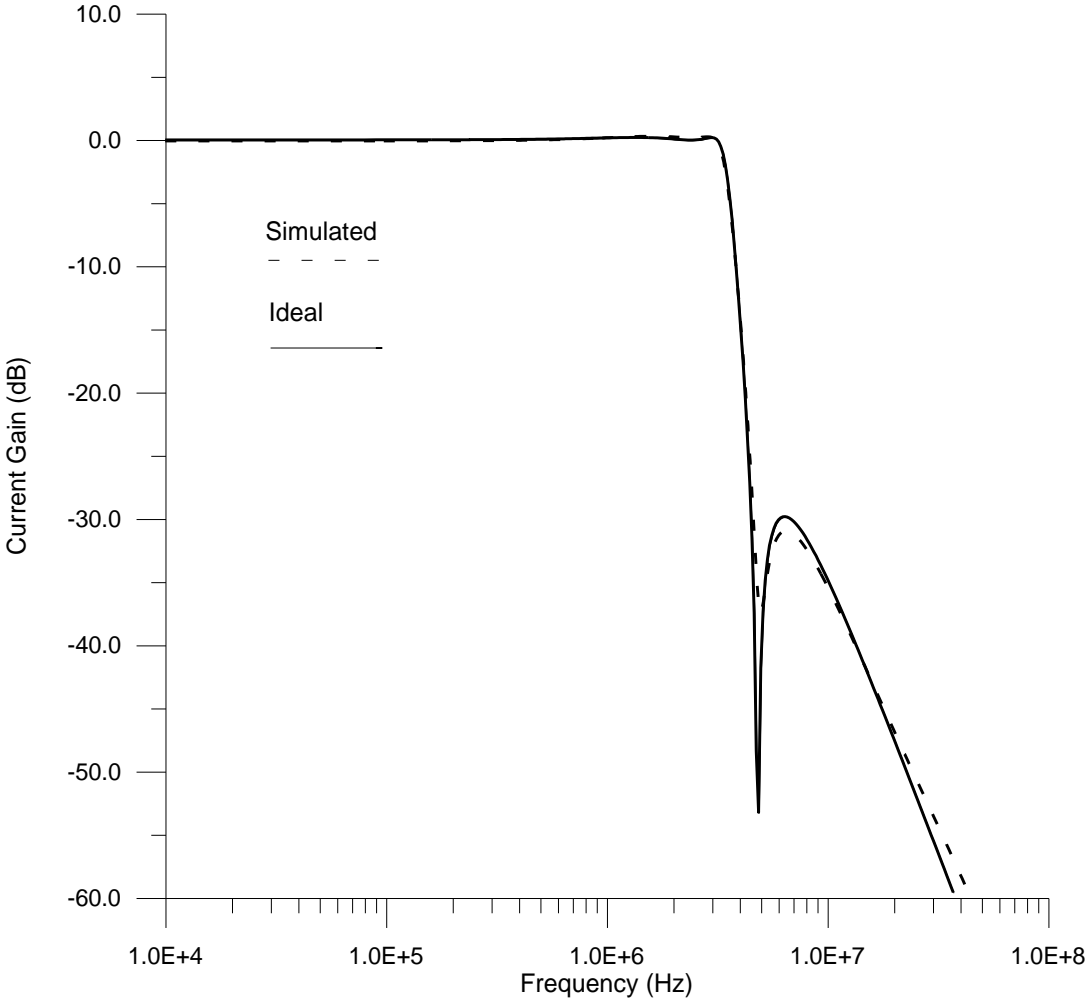

Figure 10. Simulated and ideal 4th order filter responses

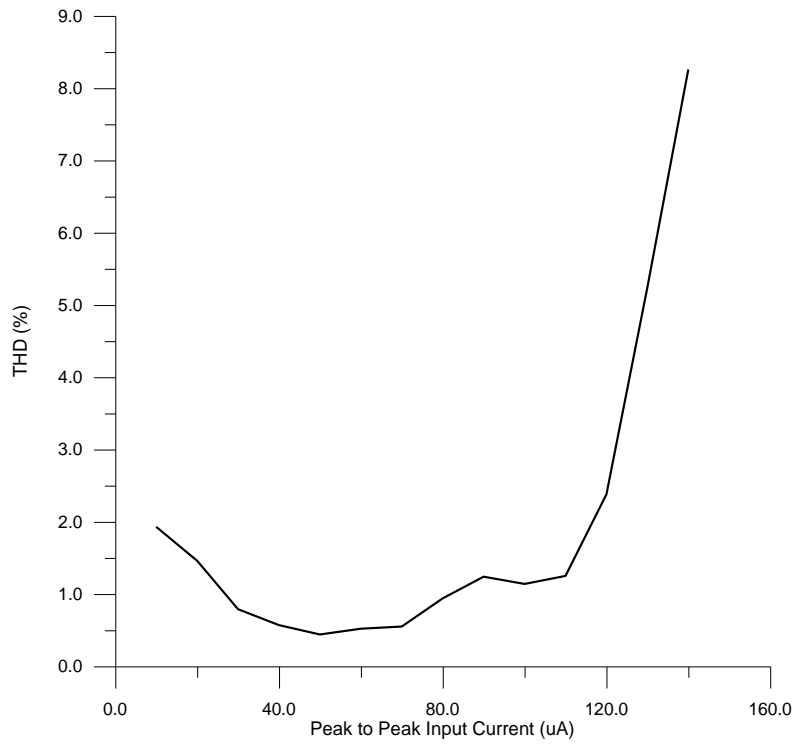

Figure 11. Total Harmonic Distortion (THD) values of the filter versus input peak to peak current at 3 MHz frequency

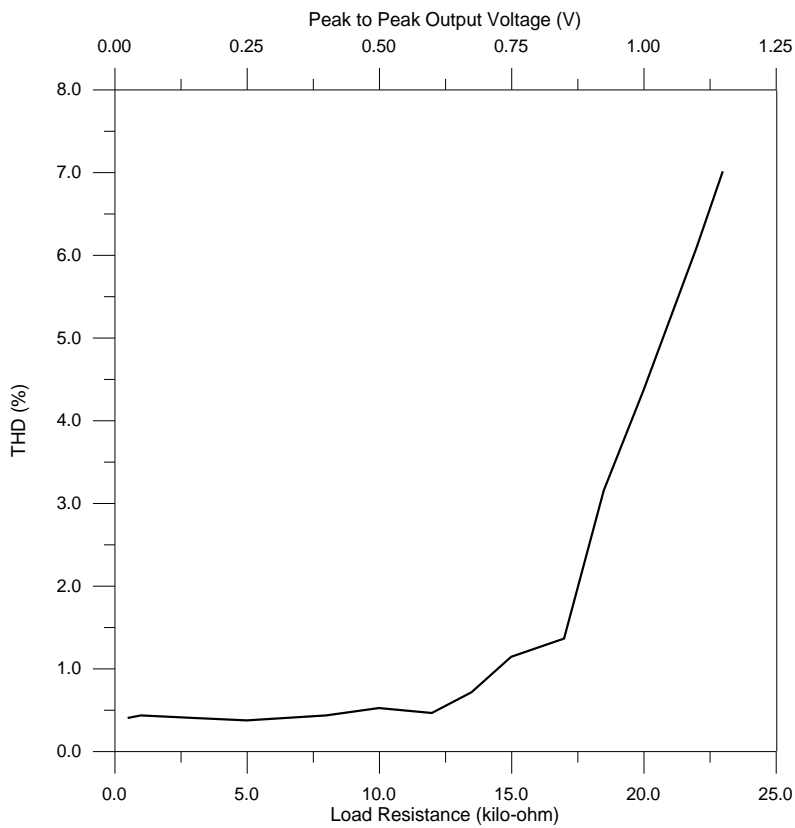

Figure 12. Total Harmonic Distortion (THD) values of the filter versus output peak to peak voltage and load resistance for 50uA peak to peak input current at 3 MHz frequency

Note that the transfer function of (8) can be also realized directly as a fourth order elliptic filter by rearranging (4) and choosing adequate biasing for ECCII. However, this causes some problems in adjusting the quality factors and pole frequencies of both sections if they are expressed in a combined form. Therefore both sections are realized separately as second-order sections and the overall filter is constructed by cascading these two sections.

6. Conclusion

In this paper, using a high performance ECCII, a new implementation of n th-order current transfer function is presented. All of the coefficients in the transfer function can be adjusted independently. Also all the passive elements are grounded, which is important in integrated circuit implementation. As an application a second order current-mode filter, which realizes low-pass, high-pass and band-pass responses is designed. Also a fourth order video band filter as a second example is given to test the cascadability of the proposed structure. The theoretical results are verified by SPICE simulations and shown to be in good agreement.

References

- [1] G. Ferri, and N.C. Guerrini, *Low-Voltage Low-Power CMOS Current Conveyor*, Kluwer Academic Publishers, Boston 2003.
- [2] A. Sedra, and K.C. Smith, "A second generation current conveyor and its applications." *IEEE Trans. on Circuit Theory*, 17, pp. 132-134, 1970.
- [3] W. Surakampotorn, and K. Kumwatchara, "CMOS-based electronically tunable current conveyor." *Elect. Lett.*, 14, pp. 1316-1317, 1992.
- [4] W. Surakampotorn, and P. Thitimajshima, "Integrable electronically tunable current conveyors." *IEE Proc.*, 135, pp. 71-77, 1988.
- [5] A. Fabre, and M. Alami, "Universal current mode biquad implemented from two CCII." *IEEE Trans. Circuit. Systems-I*, 42, pp. 383-385, 1995.
- [6] H. Tek and F. Anday, "Voltage transfer function synthesis using current conveyors." *Elect. Lett.*, 25, pp. 1552-1553, 1989.
- [7] C. Acar, and S. Özoğuz, "High-order voltage transfer function synthesis using CCII+ based unity gain current amplifiers." *Elect. Lett.*, 32, pp. 2030-2031, 1996.
- [8] F. Anday and E.O. Gunes, "Realisation of n th-order voltage transfer function using CCII+." *Elect. Lett.*, 13, pp. 1022-1023, 1995.

- [9] C.M. Chang and C. Chen, "Realization of current-mode transfer function using second-generation current conveyors." *Int. J. Electronics*, 71, pp. 809-815, 1991.
- [10] C.A. Papazoglou, and C.A. Karybakas, "Noninteracting electronically tunable CCII-based current-mode biquadratic filters." *IEE Proceedings-Circuits Devices Syst.*, 144, pp. 178-184, 1997.
- [11] R. Senani, "Novel circuit implementation of current conveyors using an OA and an OTA." *Elect. Lett.*, 16, pp. 2-3, 1980.
- [12] A. Fabre, and N. Mimeche, "Class A/AB second generation current conveyor with controlled current gain." *Elect. Lett.*, 30, pp. 1267-1269, 1994.
- [13] O. K. Sayın, "CMOS ECCII ile yüksek dereceden ayarlanabilir aktif süzgeç tasarımı." M.Sc. Thesis, Istanbul Technical University, Institute of Science and Technology, 2004.
- [14] S. Minaei, O. K. Sayın and H. Kuntman, "Nth-order current transfer function synthesis using a high-performance electronically tunable current conveyor," in *Proceedings of MELECON'06: The 13th IEEE Mediterranean Electrotechnical Conference*, Benalmádena, Málaga, Spain, 16-19 May 2006, pp.15-18 .
- [15] S. Minaei, O. K. Sayın and H. Kuntman, "A new cmos electronically tunable current conveyor and its application to current-mode filters." *IEEE Transactions on Circuits and Systems I, TCAS-I*, Volume 53, No.7, pp. 1448-1457, 2006.
- [16] C. Acar and S. Özoğuz, "Nth-order current transfer function synthesis using current differencing buffered amplifier." *Microelectronics Journal*, 31, pp. 49-53, 2000.