

Master, PhD, and Post-Doc positions available within the [TUBITAK and NSF projects](#) on Nano-Crossbar Implementations. The general information of the projects:

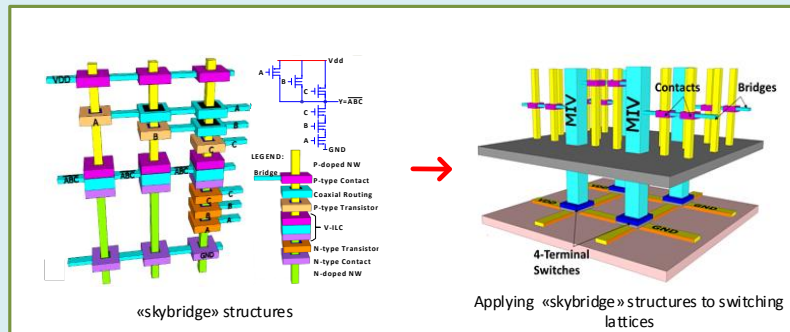
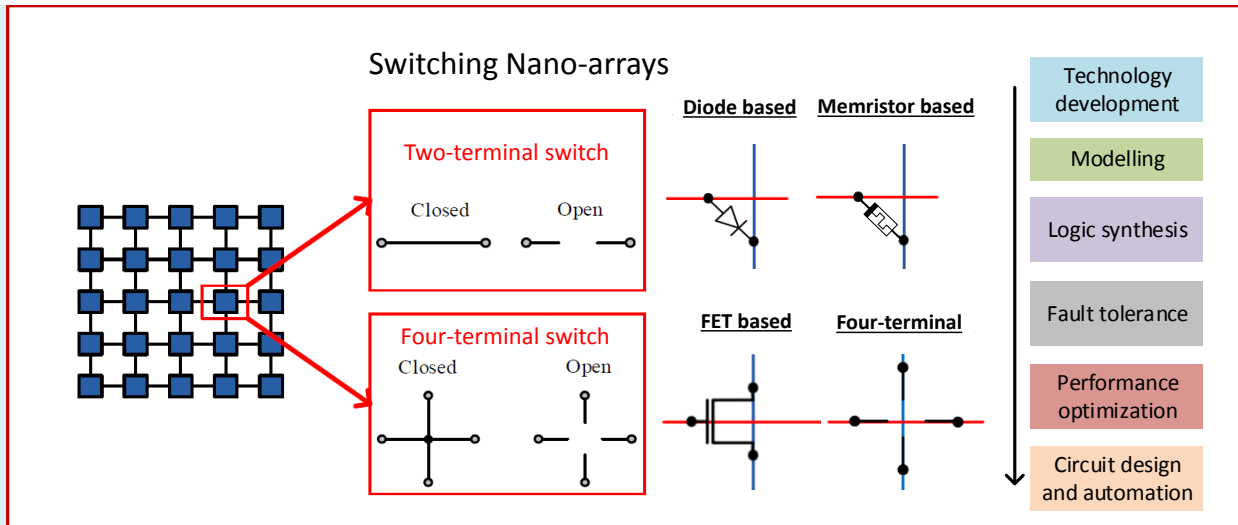

- Candidates are expected to have a background in **electronic circuit design and automation, device/circuit modelling, or technology development**.
- Researchers to be hired, will be supported through **visits and internships** to project collaborators.
- Post-Doc candidates are expected have a **strong publication record**.
- Check our web site www.ecc.itu.edu.tr for our group and project details.

If interested please contact **Mustafa Altun**:

E-mail: altunmus@itu.edu.tr

Tel: +90212 285 6635

Office: Faculty of Electrical and Electronics Eng. # 3005

Web: www.ecc.itu.edu.tr